

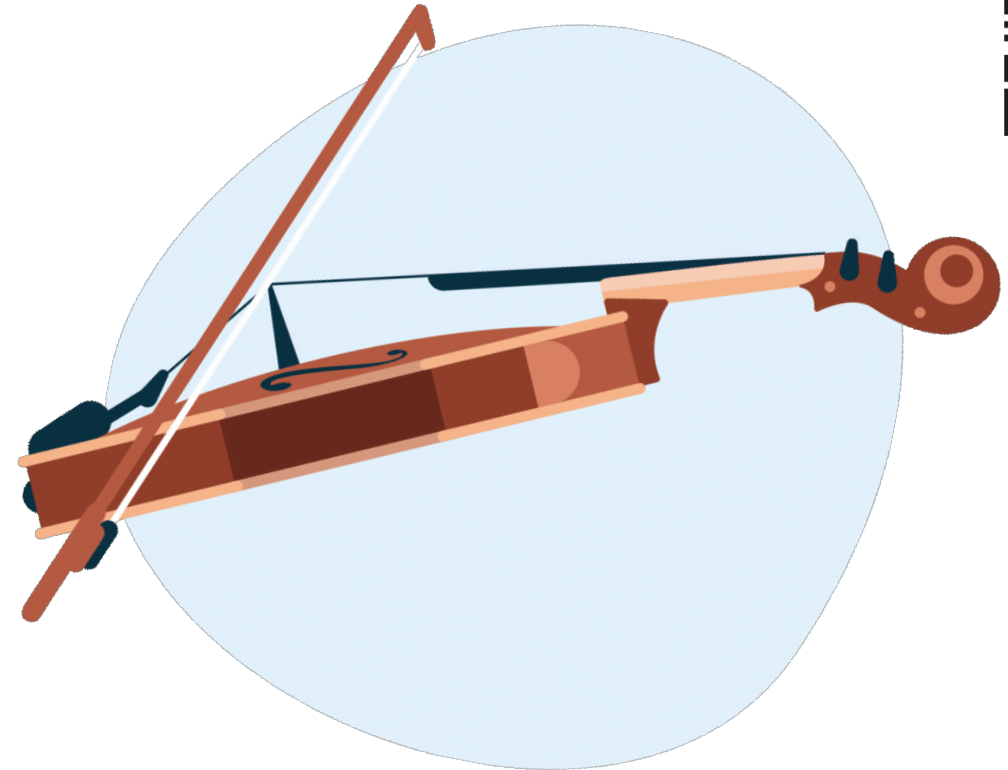

# Guide pédagogique

Orchestre Royal de Chambre  
de Wallonie - Mons

Commencer



a.s.b.l. - Hôtel de Ville - Jardin du Mateur - Grand Place, 22 - B - 7000 Mons - Tél. +32(0)65/84.70.44 - [infos@orcw.be](mailto:infos@orcw.be)



**L'ORCW**

**Les grandes périodes de l'histoire de la musique**

**Les morceaux notables**

**Les ensembles musicaux**

**Les cordes frottées**

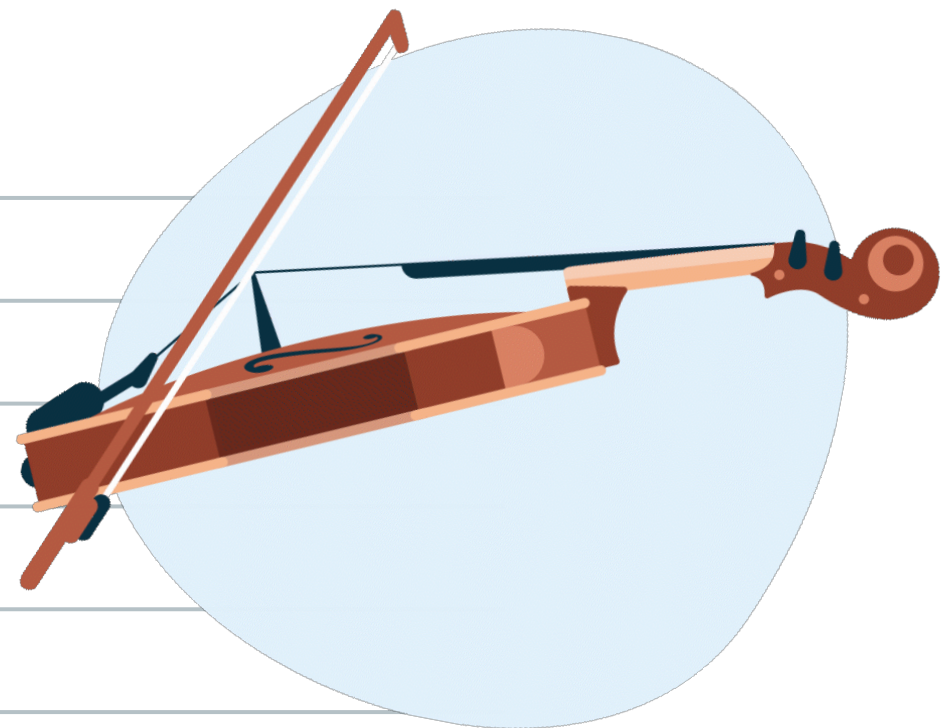

 **Visitez notre chaine Youtube**



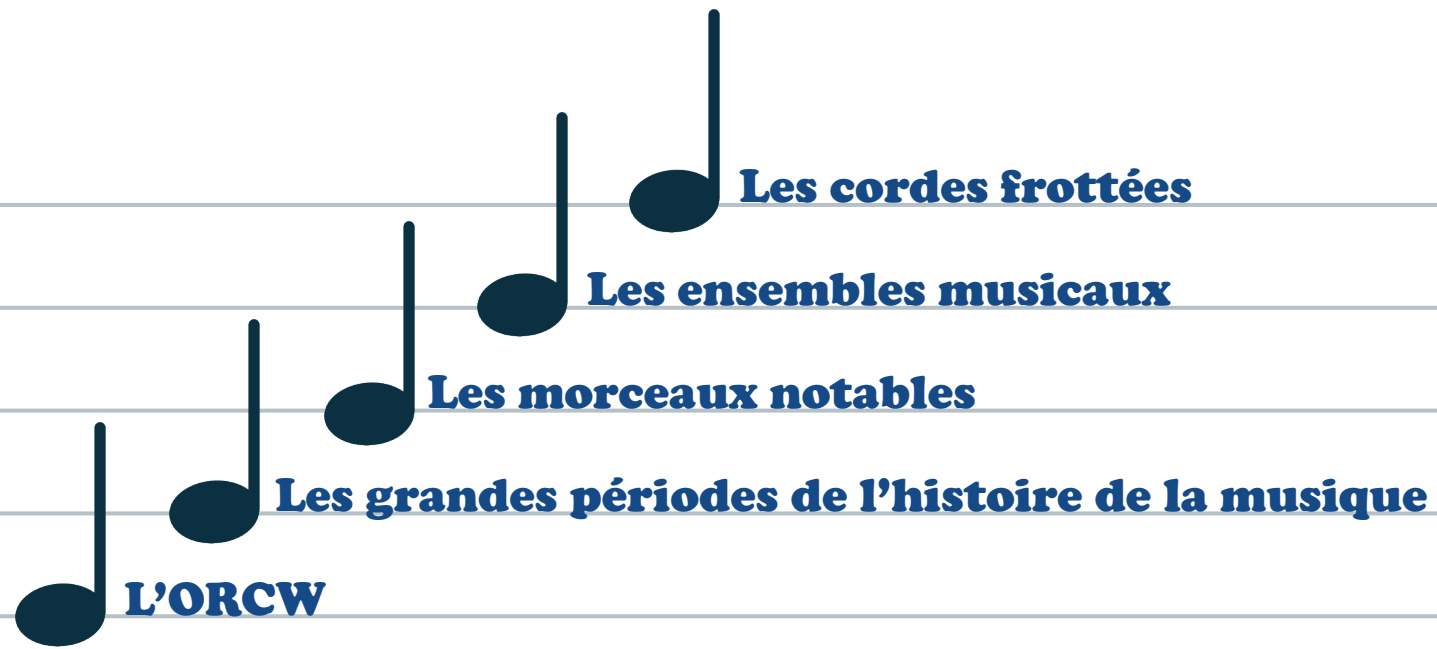

**L'ORCW**  
**Les grandes périodes de l'histoire de la musique**  
**Les morceaux notables**  
**Les ensembles musicaux**  
**Les cordes frottées**

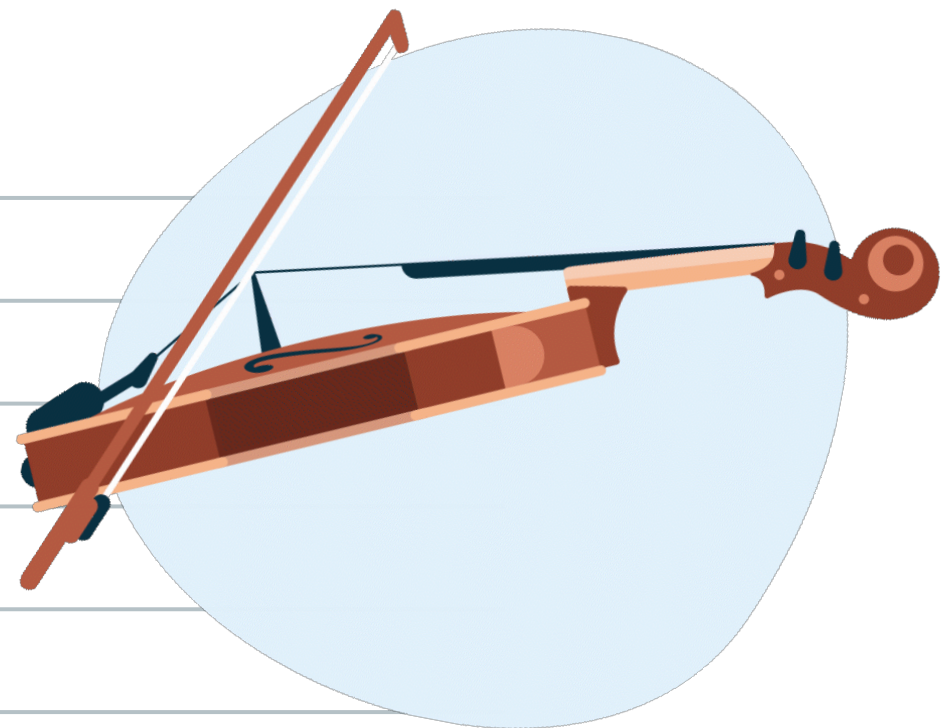

 **Visitez notre chaine Youtube**





# La famille des cordes frottées

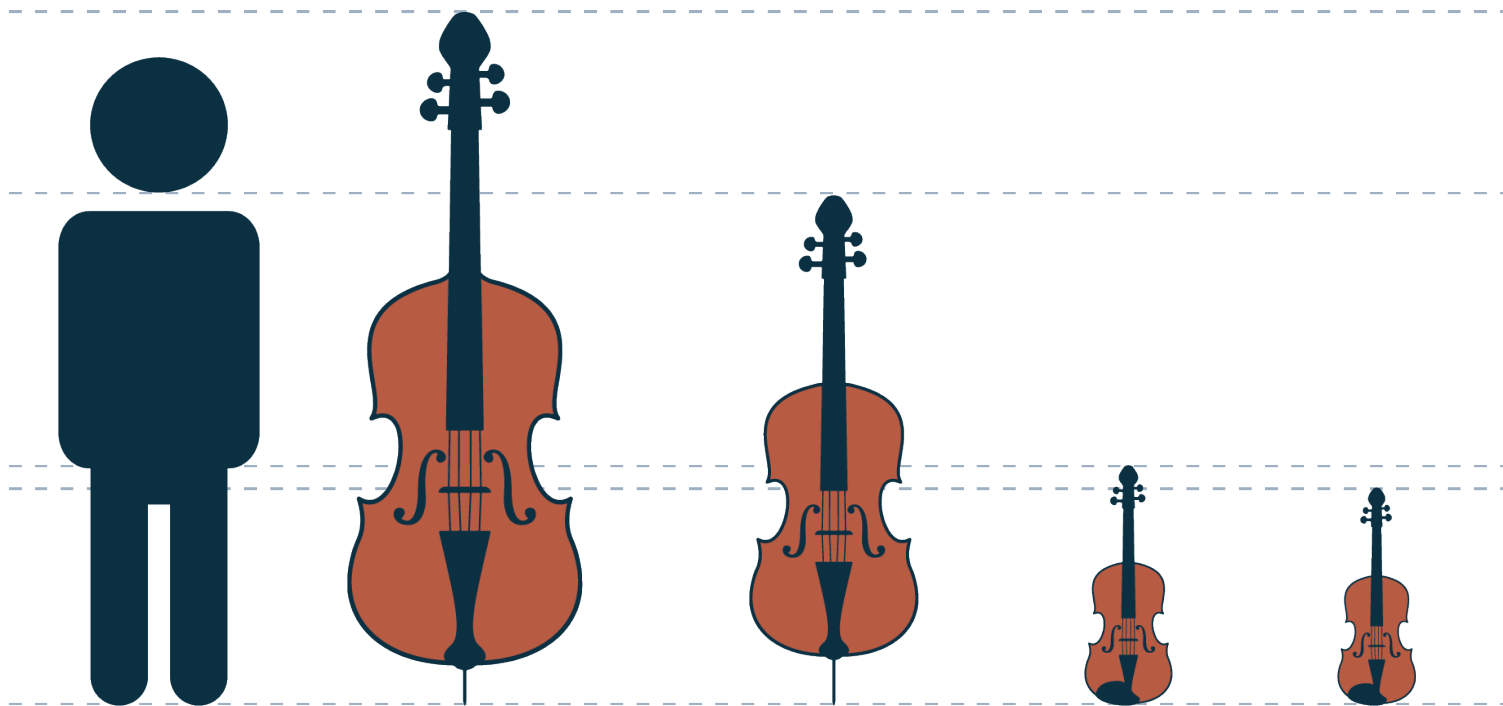

Contrebasse

Violoncelle

Alto

Violon





# La famille des cordes frottées

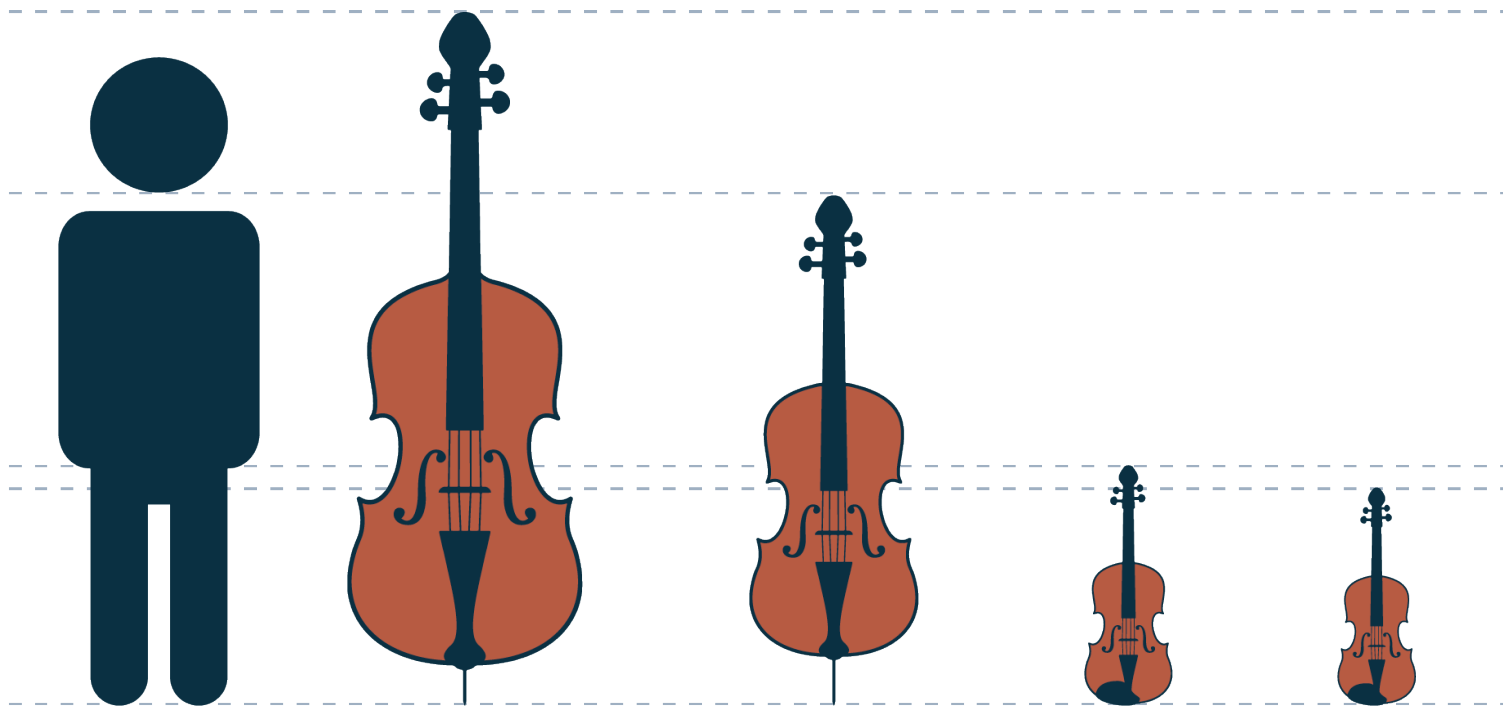

Contrebasse

Violoncelle

Alto

Violon



# La famille des cordes frottées



Cet instrument se pratique debout ou assis sur un tabouret haut.

Son registre est le plus grave et le rôle qu'on lui confie est de soutenir tous ses compagnons de jeu.



Contrebasse

Voir le concert



Violon



# La famille des cordes frottées

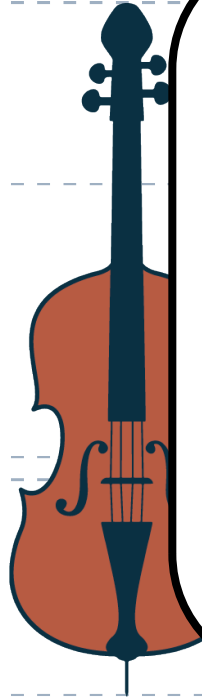

C'est presque le plus gros instrument de la famille des cordes.

Il a une tessiture grave et se joue toujours assis.

*\*Tessiture: étendue de notes d'un instrument*

Contrebasse Violoncelle

Voir le concert 



# La famille des cordes frottées

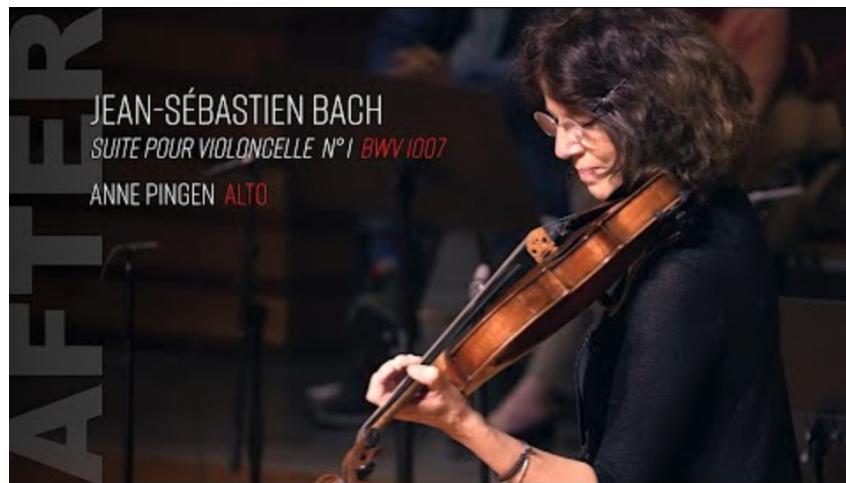

Cet instrument se pratique de la même manière que le violon.

Son registre de prédilection se situe dans les notes

médi

Contreb

Voir le concert 

Alto

Violon



# La famille des cordes frottées

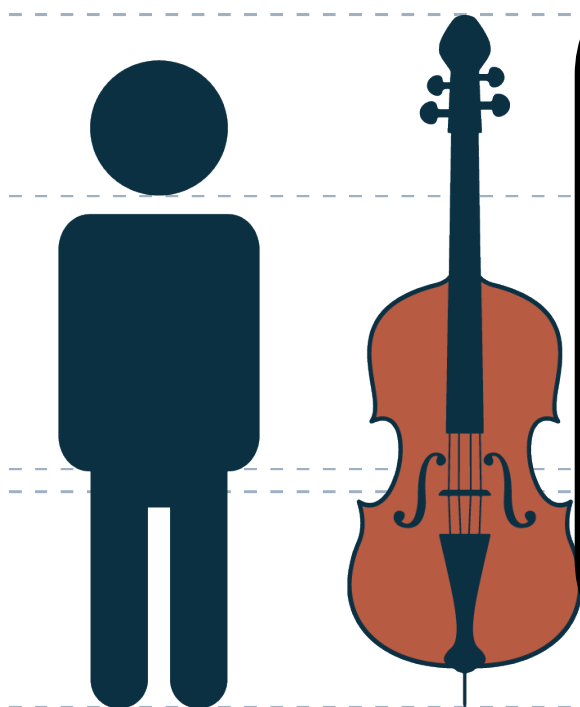

C'est le plus petit et le plus aigu des représentants de cette famille.

Il se joue debout ou assis et repose contre le cou.

Contrebasse

Voir le concert



Violon





# Comparons le violon et l'alto



Mozart - Symphonie pour violon, alto et orchestre - A. Dumay (violon), G. Caussé (alto), ORCW

Voir le  
concert





# Les tessitures\* des cordes frottées comparées à un piano

Plus l'instrument est grand, plus il produit des sons graves. À l'inverse, plus il est petit, plus il produit des sons aigus.

Notes graves ← ----- Notes aiguës →

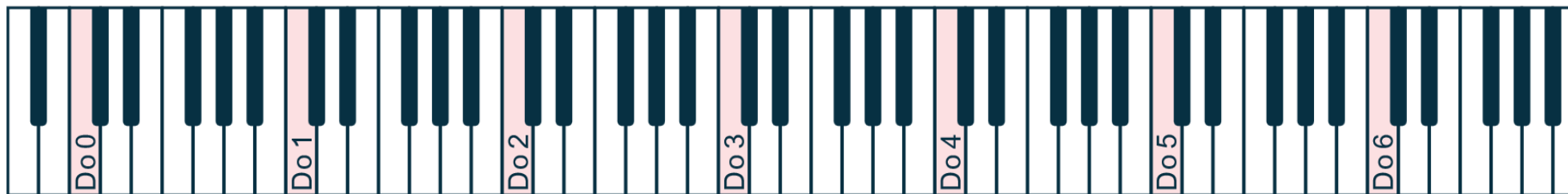

Do Ré Mi Fa Sol La Si Do



\*Tessiture: étendue de notes que peut produire une voix ou un instrument.





# Les tessitures\* des cordes frottées comparées à un piano

Plus l'instrument est grand, plus il produit des sons graves. À l'inverse, plus il est petit, plus il produit des sons aigus.

Notes graves ← ----- Notes aiguës →

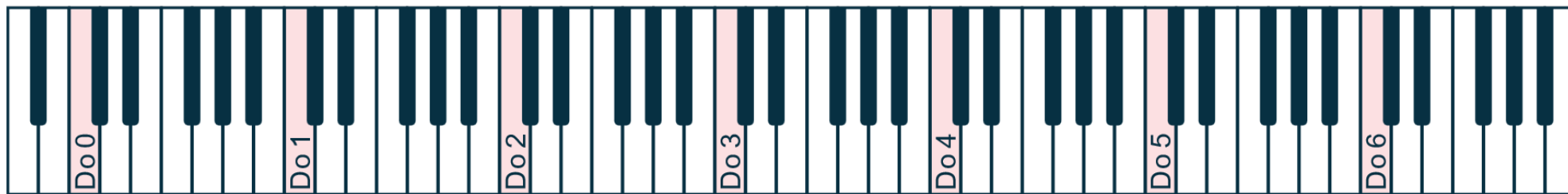

Do Ré Mi Fa Sol La Si Do



\*Tessiture: étendue de notes que peut produire une voix ou un instrument.





# Quelques ensembles musicaux...

## Le quatuor à cordes



Violon 1



Violon 2



Alto



Violoncelle





# Quelques ensembles musicaux...

## Le quatuor à cordes



Violon 1



Violon 2



Alto



Violoncelle



# Quelques ensembles musicaux...



Un quatuor à cordes est un ensemble musical (groupe de musiciens) composé de **quatre instruments à cordes**.

Généralement, on y retrouve deux violons, un alto et un violoncelle.



Violon 1



Voir le concert 

Violoncelle





# Notre orchestre de chambre

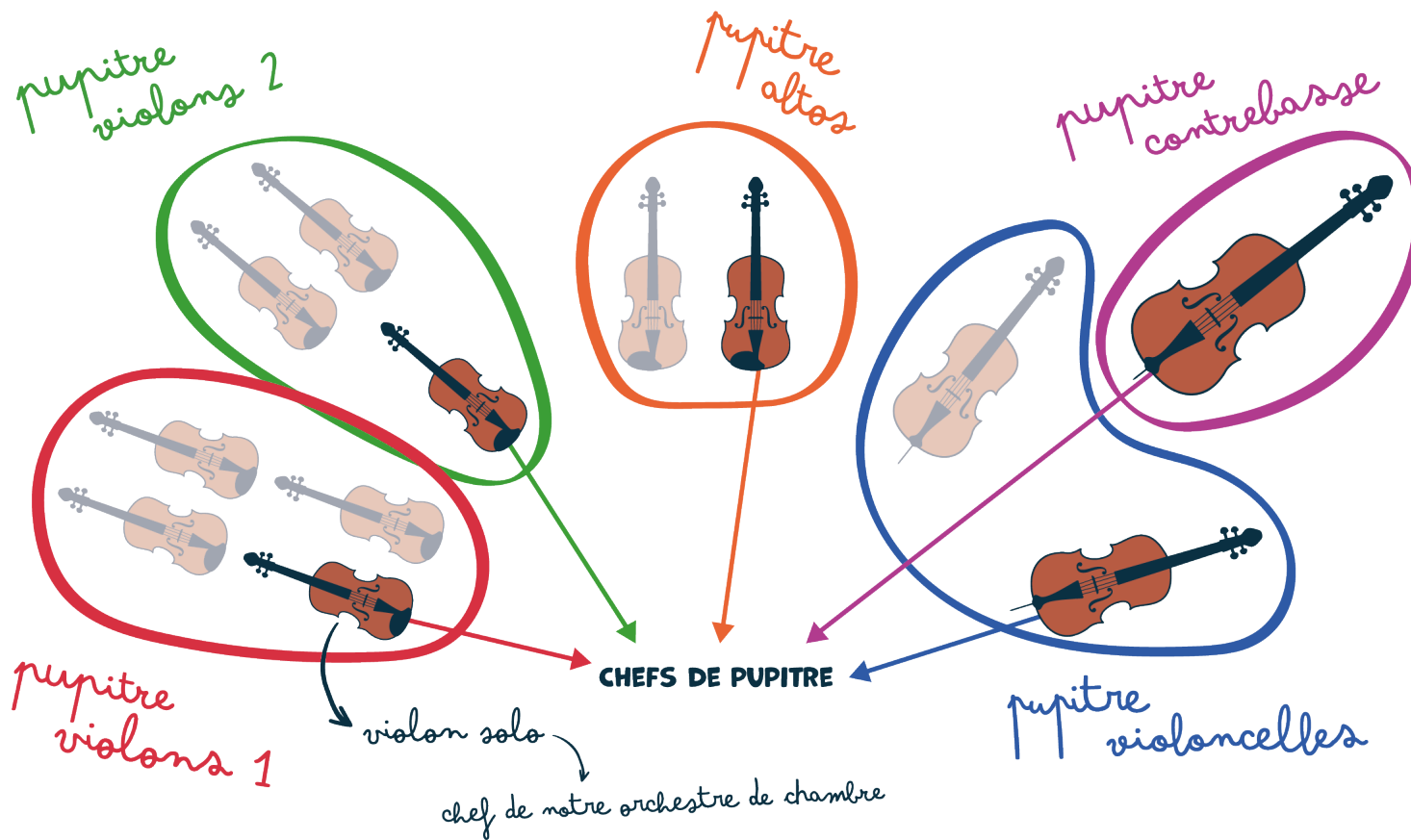



# Notre orchestre de chambre

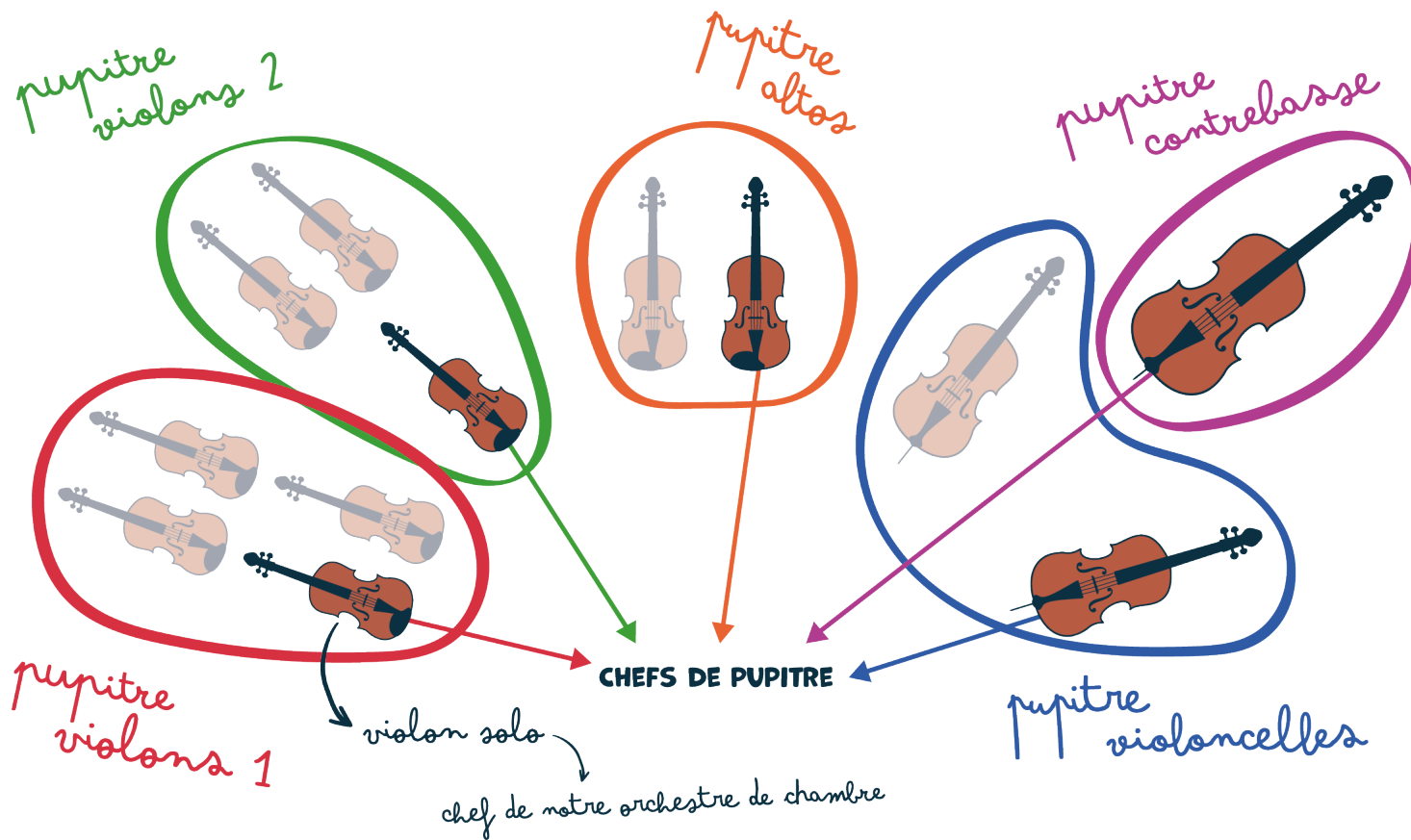

# Notre orchestre de chambre



*pu*

Un orchestre de chambre comporte **entre une douzaine et une quarantaine de musiciens.**

On y retrouve au moins des premiers et seconds violons, des altos, des violoncelles et une contrebasse.

*pupitre  
violons I*

Des cordes, des vents et des percussions peuvent s'ajouter *pour agrandir* l'orchestre de chambre.

*violon solo*

*chef de notre orchestre de chambre*

[Voir le concert](#) 

*es*

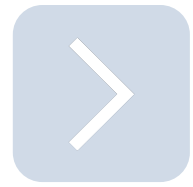
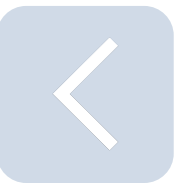



# L'Orchestre symphonique

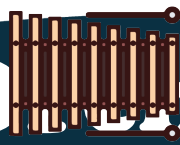

XYLOPHONE



CYMBALES



CAISSE CLAIRE



GROSSE CAISSE



TOMBALES



CORS



TROMPETTES



TROMBONES



TUBA



PICCOLO



FLÛTES TRAVERSIÈRES



HAUTBOIS



CLARINETTES

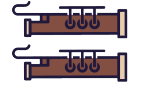

BASSONS



CONTREBASSON



HARPE

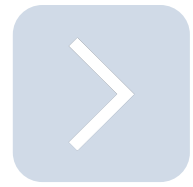
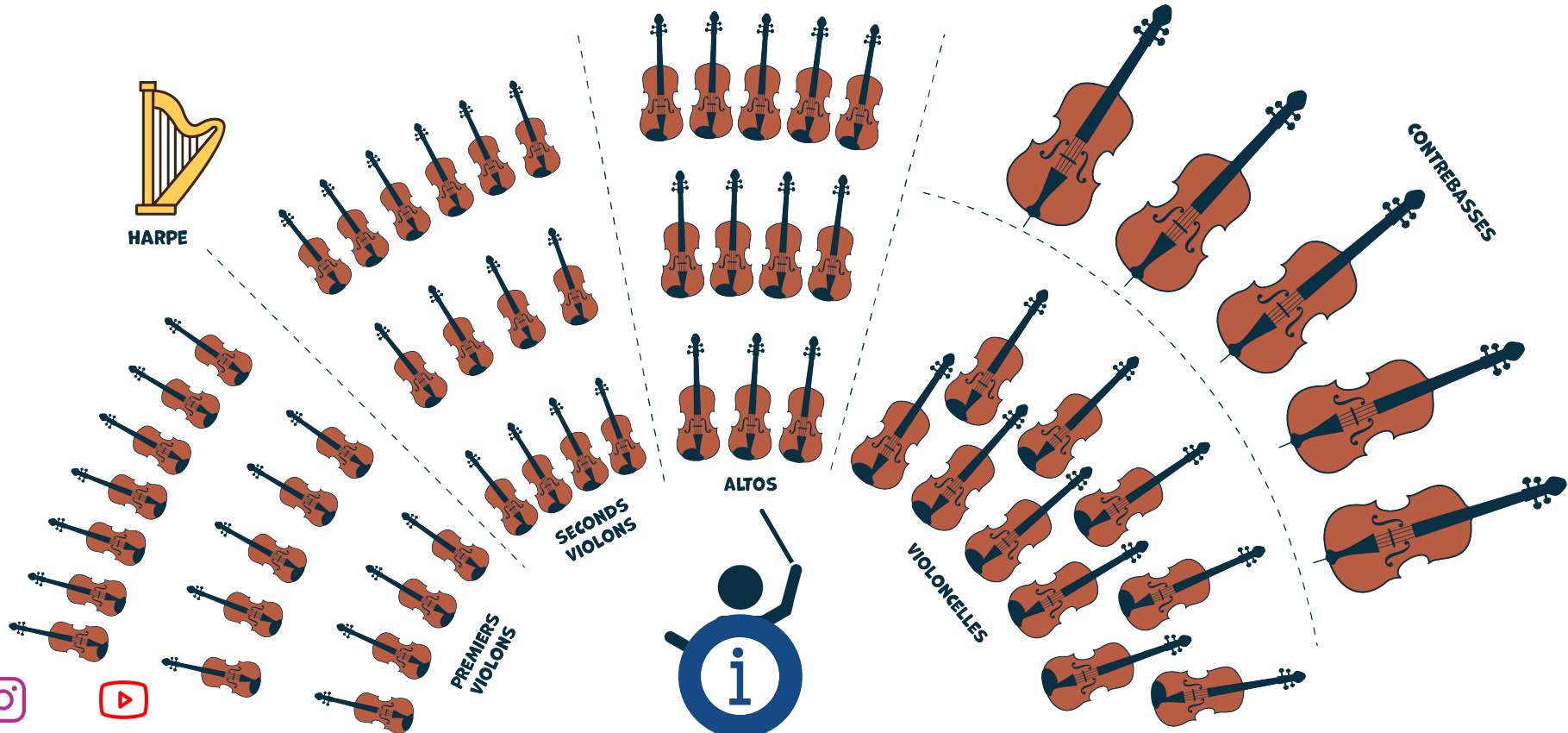



# L'Orchestre symphonique

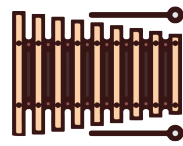

XYLOPHONE



CYMBALES



CAISSE CLAIRE



GROSSE CAISSE



TIMBALES



CORS



TROMPETTES

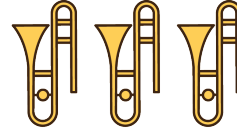

TROMBONES



TUBA



PICCOLO



FLÛTES TRAVERSIÈRES



HAUTBOIS



CLARINETTES



BASSONS



CONTREBASSON



HARPE

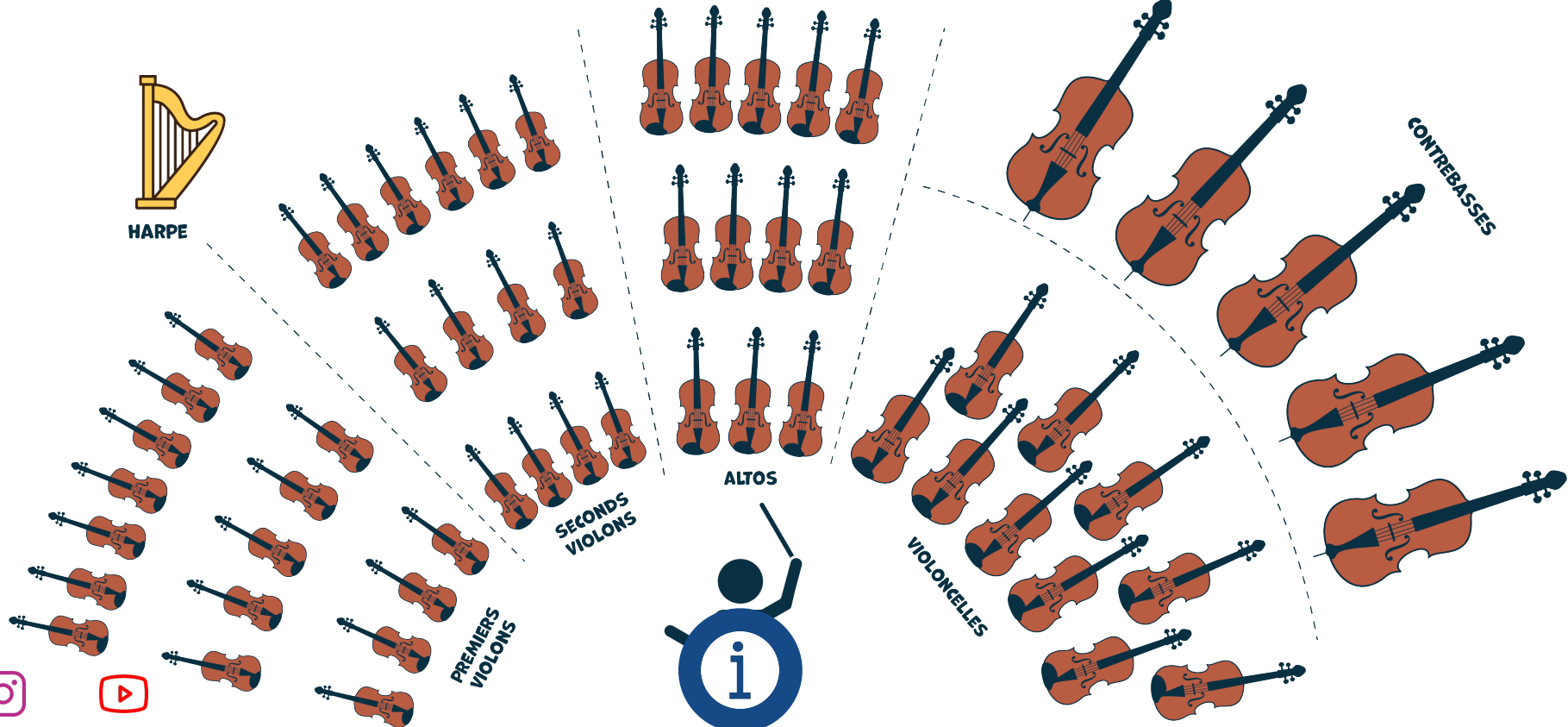

# L'Orchestre symphonique

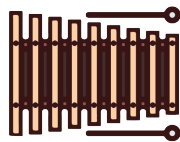

XYLOPHONE



CYMBALES



CAISSE CLAIRE



GROSSE CAISSE



TIMBALES



CORS



TROMPETTES



TROMBONES



TUBA



PICCOLO

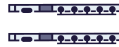

FLÛTES TRAVERSIÈRES



HAUTBOIS



CLARINETTES



BASSONS



CONTREBASSON



HARPE

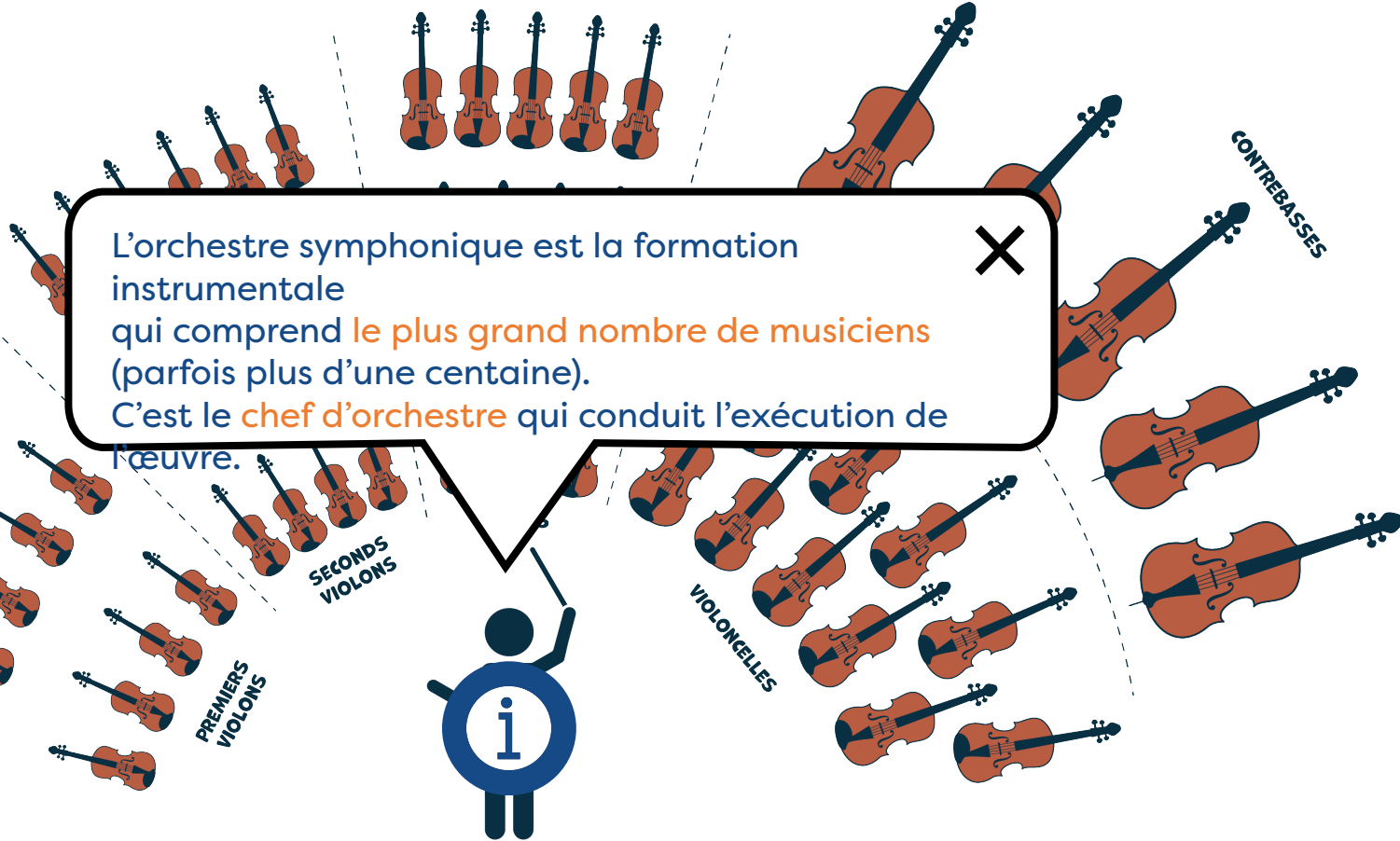



# Il est donc composé de **trois** familles d'instruments

## Les cordes



- **Les cordes frottées** : violon, alto, violoncelle et contrebasse...
- **Les cordes pincées** : harpe...

## Les vents



- **Bois** : piccolo, flûte traversière, clarinette, hautbois, cor anglais, basson, contrebasson...
- **Cuivres** : trompette, trombone, cor d'harmonie, tuba...

## Les percussions



- Cymbale, timbale, grosse caisse, caisse claire, tambour, xylophone, métallophone, vibraphone, triangle, castagnettes, célesta, wood-block, carillon tubulaire (ou jeu de cloches), tubes résonnants, maracas...



## Violon



Mozart : Adagio en mi majeur - Augustin Dumay



[Voir le concert](#)



## Alto



Hummel : Fantaisie pour alto et cordes - Gérard Caussé, ORCW



[Voir le concert](#) 



## Violoncelle



Beethoven, Trio à cordes n°2 op.8 - Trio de l'ORCW : Pascal Crismer, Anne Pingen, Hans Vandaele



Voir le concert 



## Contrebasse



Onslow, Quintette à cordes n°10 - Quintette ORCW



[Voir le concert !\[\]\(befdcdf329f4bc1566e8bd49d7971740\_img.jpg\)](#)



## Harpe



Debussy : Danses sacrée et profane - Sophie Hallynck, ORCW



[Voir le concert !\[\]\(2de14ecdac8f3bd4221dec5cc1fcc44b\_img.jpg\)](#)



## Hautbois



Telemann : Concerto pour 2 chalumeaux et cordes - P. Meyer, M. Portal, ORCW



[Voir le concert !\[\]\(1d44e689db7887f5f7d7a4ea2fb82e45\_img.jpg\)](#)



## Clarinete



Aaron Copland Aaron - Concerto pour clarinette - Ronald Van Spaendonck, ORCW



Voir le concert 



## Flûte



Tanguissimo - partie 2 - Le tango et Piazzolla à l'honneur



[Voir le concert !\[\]\(5e17ffbca1f899607873677550e81004\_img.jpg\)](#)





# Allons plus loin...

La tessiture désigne l'étendue des notes, des plus graves aux plus aiguës, propre à chaque instrument.

Pour faciliter la lecture, différentes clefs sont utilisées.

Voici les principales :

- La clef de Sol permet de lire les notes les plus aiguës.
- La clef d'Ut, les notes intermédiaires.
- La clef de Fa, les notes graves.



Il est alors logique que les instruments aient des clefs différentes.

Voici les clefs qu'utilisent principalement :



Clef de Sol



Violon



Clef d'Ut



Alto



Clef de Fa

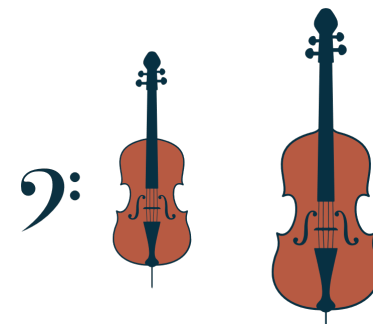

Violoncelle





# La première octave...

Clef de Sol

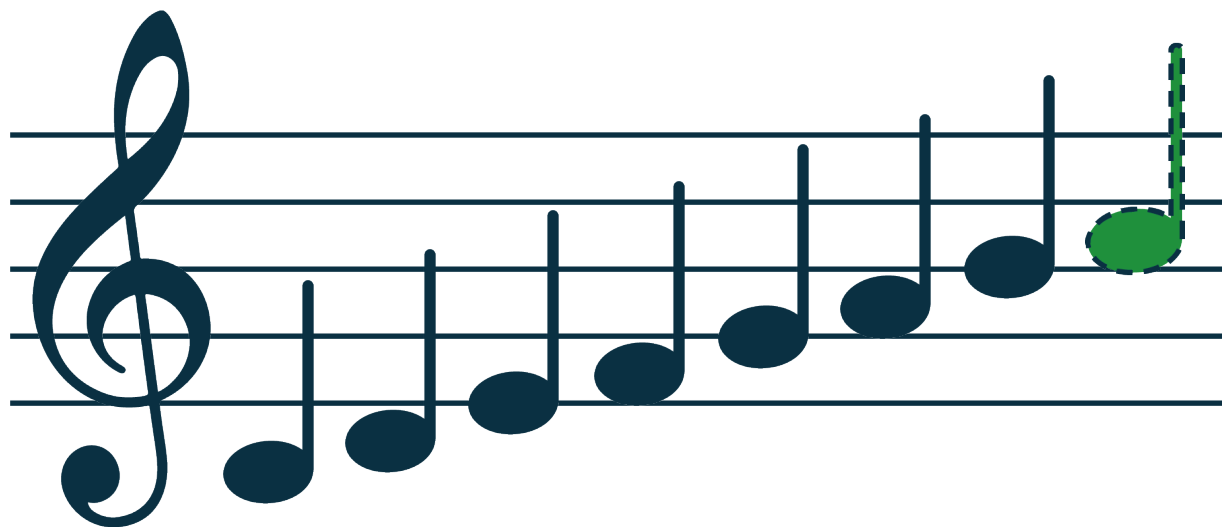

Do Ré Mi Fa Sol La Si Do





# La première octave...

Clef de Sol

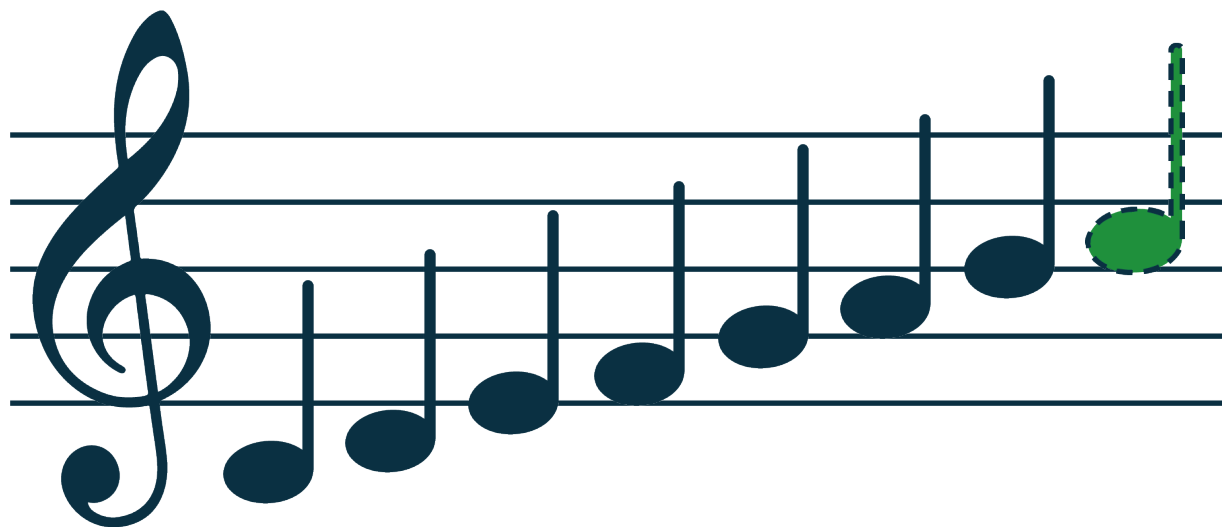

Do Ré Mi Fa Sol La Si Do



# 🏠 La première octave...

## Clef de Sol

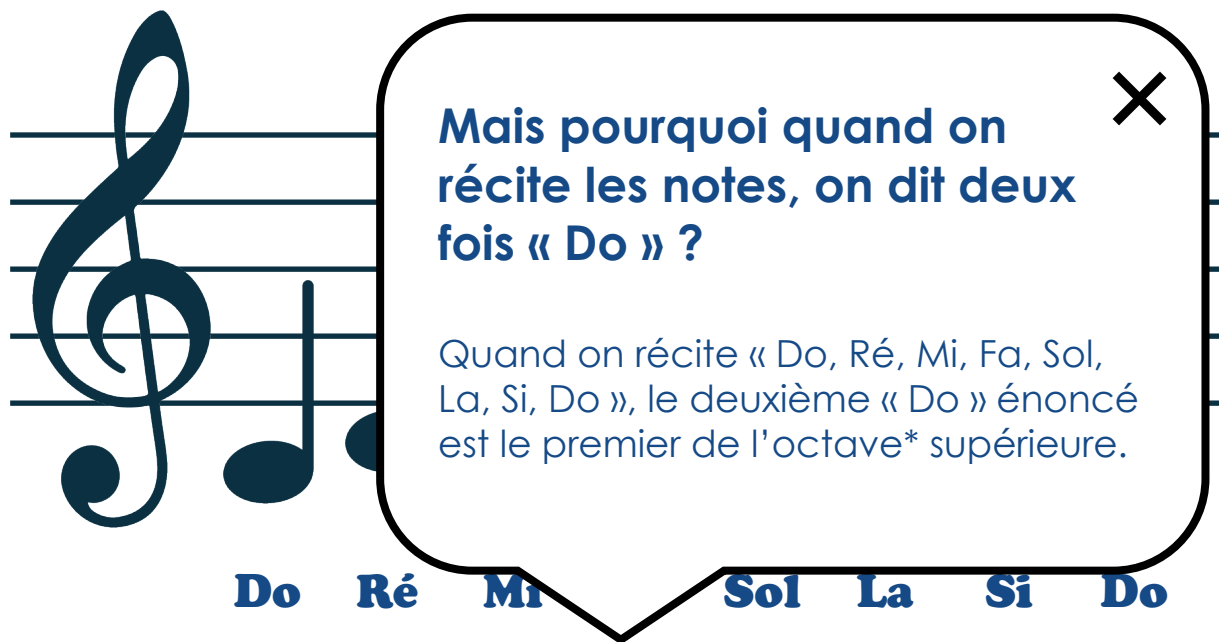

Mais pourquoi quand on récite les notes, on dit deux fois « Do » ?

Quand on récite « Do, Ré, Mi, Fa, Sol, La, Si, Do », le deuxième « Do » énoncé est le premier de l'octave\* supérieure.

Do Ré Mi Sol La Si Do





**Découvrons maintenant...**

# Le violon

Le violon est un instrument de musique appartenant à la famille des instruments à cordes frottées.

Il est beaucoup utilisé dans les orchestres et la musique de chambre, mais aussi, de nos jours, dans la variété, le jazz, etc.

Le violon possède quatre cordes (sol, ré, la, mi) qui sont frottées avec un archet. Sa création remonte au 16<sup>e</sup> siècle en Italie et il adoptera sa forme actuelle vers les années 1630.

Il est le **PLUS PETIT** instrument de sa famille. Il est donc le **plus aigu**.





**Découvrons maintenant...**

# Le violon et son Compagnon l'archet >>>

Le violon et l'archet sont indissociables !  
Il fait vibrer les cordes du violon.

Le son se crée dans le corps du violon et sort par les ouïes.  
Il n'est pas nécessaire de brancher le violon à un système électrique.  
C'est ce que l'on appelle un instrument acoustique.

À noter qu'il est aussi possible de jouer du violon en pinçant ses cordes  
avec les doigts. Cette technique s'appelle le « pizzicato ».





## Les différentes parties du violon



LA TÊTE est la « spirale » en haut du violon.

LES CHEVILLES sont les vis qui servent à tendre les cordes.

LA TOUCHE est la partie noire contre laquelle On appuie la corde en y posant les doigts.





## Les différentes parties du violon



**LE CHEVALET** soutient les cordes  
Et les élève au-dessus de la touche.



**LE CORDIER** est l'endroit où sont  
accrochées les cordes.

**LES TENDEURS** sont les trous dans le  
cordier qui servent  
À tendre les cordes.



**LE BOUTON** sert à maintenir le cordier  
et les cordes.





## Les différentes parties de l'archet

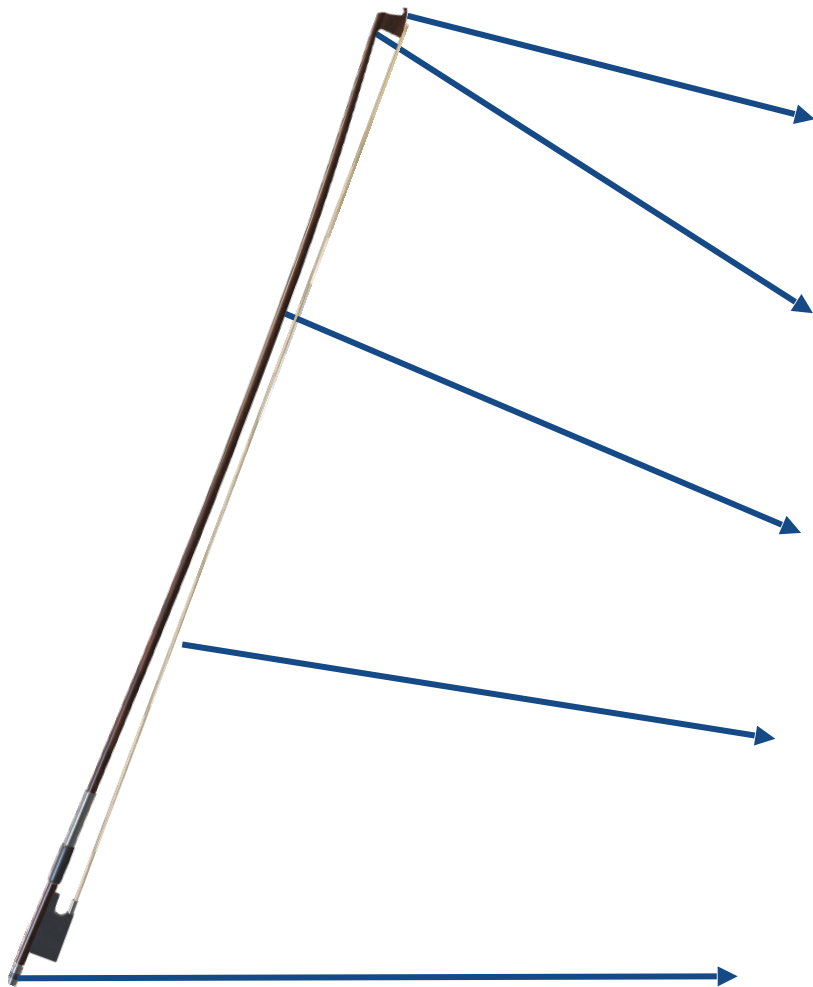

LA PLAQUE DE TÊTE est la protection de la tête.

LA TÊTE est l'endroit qui est à l'opposé de la main quand on tient l'archet.

LA BAGUETTE est le plus souvent en bois de pernambouc\*.

LA MÈCHE de corde est constituée de crins de cheval.

LE BOUTON sert à resserrer la mèche pour créer une tension et la faire tenir.

*\*Pernambouc : bois précieux venant du Brésil.*





# Les grandes périodes de l'histoire de la musique

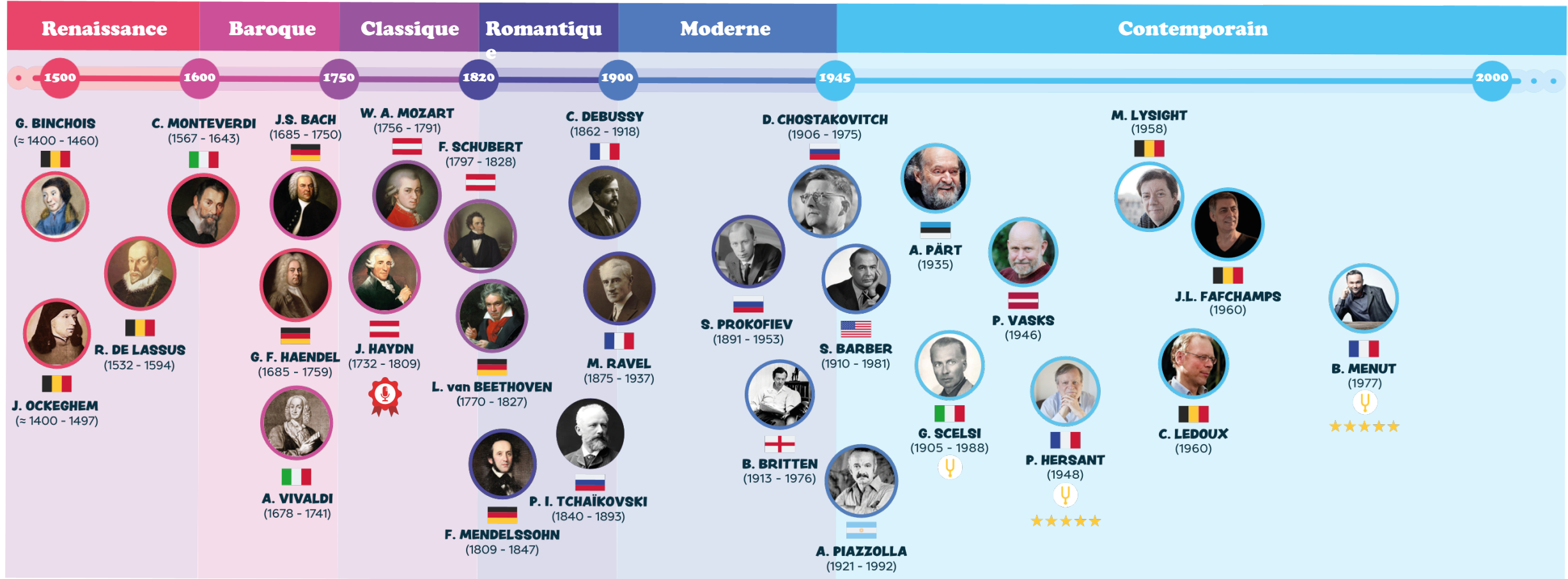

(Diapason d'Or)/ ★★★★★ (5 étoiles Classica) : il s'agit de récompenses prestigieuses dans le domaine de la musique classique, honorant les enregistrements exceptionnels. L'ORCW en a remporté pour l'enregistrement d'œuvres de ces artistes.

Selon le BBC Music Magazine, l'ORCW a réalisé le meilleur enregistrement des 100 dernières années du concerto pour violoncelle.





## Quelques grands compositeurs de l'Histoire interprétés par l'ORCW



**Antonio VIVALDI** (1678 - 1741) 

🎵 « *Les Quatre Saisons* », ...

Violoniste, compositeur et prêtre à Venise, il a écrit plus de 500 concertos.

[Voir le concert](#) 



**Georg Philipp TELEMANN** (1681 - 1767) 

🎵 « *Don quixote* »,...

Compositeur baroque allemand reconnu pour sa diversité stylistique, son immense production musicale comprend plus de 3 000 œuvres.

[Voir le concert](#) 



**Jean-Sébastien BACH** (1685 - 1750) 

🎵 « *Prélude en Do majeur* », « *Passion selon saint Matthieu* »,  
« *Concertos brandebourgeois* », ...

Compositeur et organiste allemand, il a laissé un héritage musical indélébile. Sa mort marqua la fin de l'époque baroque.

[Voir le concert](#) 





## Quelques grands compositeurs de l'Histoire interprétés par l'ORCW



**Joseph HAYDN** (1732 - 1809) 

🎵 « Symphonie 36, 43, 47, 48, 49, 60 », ...

Compositeur viennois, il a inventé le modèle symphonique. Il était surnommé « Papa Haydn » par son ami Mozart dont il était le professeur. Beethoven suivit aussi son enseignement.

 Selon le *BBC Music Magazine*, l'ORCW a réalisé le meilleur enregistrement des 100 dernières années du concerto pour violoncelle.

[Voir le concert](#) 



**Wolfgang Amadeus MOZART** (1756 - 1791) 

🎵 « Requiem », « Divertimento », « La Flûte enchantée »,  
« Petite musique de nuit », ...

Enfant prodige par excellence, il a porté à son apogée l'époque classique viennoise et a écrit plus de 600 œuvres.

[Voir le concert](#) 

[Voir le concert](#) 

[Voir le concert](#) 





## Quelques grands compositeurs de l'Histoire interprétés par l'ORCW



**Ludwig van BEETHOVEN** (1770 - 1827) 

🎵 « Lettre à Élise », « Concertos pour piano », ...

Il a contribué à la transition entre la période classique et la période romantique. Il continua de composer malgré ses problèmes d'audition survenus à l'âge de 27 ans. Il fut totalement sourd à l'âge de 50 ans.

[Voir le concert](#) 



**François-Joseph FÉTIS** (1784- 1871) 

🎵 « Messe de Requiem », ...

Originaire de Mons , il est professeur de composition et bibliothécaire au Conservatoire de Paris. Fétis est le premier directeur du Conservatoire royal de Bruxelles et a rédigé des biographies de compositeurs notables et contribué à l'encyclopédie musicale.

[Voir le concert](#) 



**Franz SCHUBERT** (1797 - 1828) 

🎵 « Sérénade », « La Jeune Fille et la Mort », « La truite », ...

Compositeur emblématique de la musique romantique viennoise, bien qu'il soit mort précocement à 31 ans. Il est l'un des compositeurs les plus prolifiques du XIX<sup>e</sup> siècle.

[Voir le concert](#) 





## Quelques grands compositeurs de l'Histoire interprétés par l'ORCW

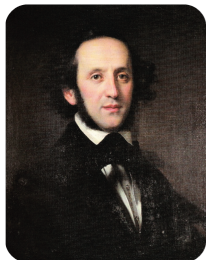

**Felix MENDELSSOHN** (1809 - 1847) 

🎵 « *Concertos pour violon* »,  
« *Symphonies pour cordes 1, 2, 3, 4, 5, 6, 7, 8, 9, 10, 11, 12, 13* », ...

Son génie musical précoce démontre une maîtrise technique et une sensibilité artistique reconnues à son époque, marquant la musique romantique européenne.

[Voir le concert](#) 



**Frédéric CHOPIN** (1810 - 1849)  / 

🎵 « *Concertos pour piano n°1, 2* », ...

Compositeur et pianiste virtuose franco-polonais, il a révolutionné la musique pour piano, devenant une figure centrale du romantisme

[Voir le concert](#) 



**Henri VIEUXTEMPS** (1820 - 1881) 

🎵 « *Concerto pour violon n°5* », ...

Violoniste et compositeur belge du XIX<sup>e</sup> siècle, il est reconnu pour sa virtuosité remarquable au violon et ses compositions qui ont suscité l'admiration de ses pairs à l'époque.

[Voir le concert](#) 





## Quelques grands compositeurs de l'Histoire interprétés par l'ORCW



**Richard STRAUSS** (1864 - 1949) 

🎵 « *Also sprach Zarathustra* », « *Metamorphosen* », « *Capriccio* », ...

Compositeur allemand, Strauss fut un excellent chef d'orchestre. Sa musique marque une transition entre le romantisme tardif et le modernisme musical.

[Voir le concert](#) 



**Claude DEBUSSY** (1862 - 1918) 

🎵 « *Clair de lune* », « *Six épigraphes antiques* », ...

Compositeur français très avant-gardiste, il a été anticonformiste pendant la plus grande partie de sa vie, rejetant l'esthétisme prôné par l'académie.

[Voir le concert](#) 



**KOMITAS** (1869 - 1935) 

🎵 « *Trois miniatures* », ...

Compositeur et prêtre arménien, il est célèbre pour avoir préservé et documenté de manière exhaustive la musique folklorique arménienne, tout en créant ses propres compositions musicales, marquant ainsi l'histoire musicale de l'Arménie.

[Voir le concert](#) 





## Quelques grands compositeurs de l'Histoire interprétés par l'ORCW



**Maurice RAVEL** (1875 - 1937) 

🎵 « *Le Boléro* », « *Tzigane* », « *Pavane* », ...

Avec Claude Debussy, Ravel fut la figure la plus influente de la musique française de son époque.

[Voir le concert](#) 



**Benjamin BRITTEN** (1913 - 1976) 

🎵 « *Simple Symphony* », ...

Compositeur, chef d'orchestre et pianiste anglais, sa musique était souvent expressive, explorant des thèmes sociaux et humains profonds, tout en étant accessible à un large public.

[Voir le concert](#) 

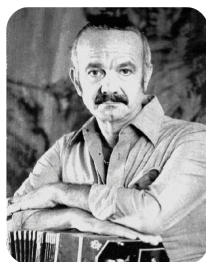

**Ástor PIAZZOLLA** (1921 - 1992) 

🎵 « *Libertango* », ...

Compositeur argentin, il a révolutionné l'écriture du Tango qu'il a fait entrer dans les salles de concerts.

[Voir le concert](#) 



## Orchestre de chambre



Anderson, Leroy : Jazz Pizzicato - ORCW, Vahan Mardirossian



[Voir le concert !\[\]\(b08b6b979eee0a9a08a4a2cf23b99784\_img.jpg\)](#)



## **Orchestre de chambre**



**Elgar : Sérénade - ORCW, J.P. Wallez - LIVE 4K**



**Voir le concert** 



## Orchestre de chambre



Jenkins : Palladio - ORCW, JF Chamberlan



Voir le concert 



## Piano



Beethoven - Concerto n°4 pour piano - Frank Braley, ORCW



[Voir le concert !\[\]\(98a0f62050c8ae5b6b5f206bfc69317a\_img.jpg\)](#)



## Opéra



La Flûte enchantée, opéra de Mozart - Festival Midsummer Mozartiade 2023



[Voir le concert !\[\]\(e83b2296dc4c9009963f494078a8a780\_img.jpg\)](#)



## Décalé



Philip Catherine & l'ORCW - "Transparence", arr. Michel Herr



Voir le concert 



## Décalé



MACHIAVEL FETE SES 40 ANS AVEC L'ORCW - Concert de clôture - LIVE - (POP-ROCK)



Voir le concert 



## Décalé



DiscoClassiX - "Psycho Disco"



[Voir le concert](#) 



## Décalé



Pairi Daiza - Les animaux et la musique



Voir le concert 



## Biographie

En 1958, **Lola Bobesco** crée l'ensemble « Les Solistes de Bruxelles », nommé successivement « Ensemble d'archets Eugène Ysaÿe » et « **Orchestre Royal de Chambre de Wallonie** » (ORCW).

A la suite des derniers Directeurs musicaux, **Augustin Dumay** (2003–2013) et **Frank Braley** (2014-2019), **Vahan Mardirossian** a pris la baguette pour continuer le travail d'excellence.

L'ORCW a régulièrement collaboré avec les plus grands artistes, sur les scènes internationales les plus importantes ainsi qu'à Mons, Capitale culturelle de la Fédération Wallonie-Bruxelles, Capitale européenne de la culture 2015, sa ville de résidence depuis plus d'un demi-siècle :

Paris, Amsterdam, Pékin, Abu Dhabi, Istanbul, Bucarest, Bayreuth, Munich, Luxembourg, Zurich, Genève, Saint-Pétersbourg, Varsovie, Bruxelles...

L'ORCW est partenaire du **Concours Musical International Reine Élisabeth** depuis plus de **20 ans**, un complice régulier de la Chapelle Musicale Reine Élisabeth et de nombreux festivals belges et internationaux.

A Mons, en partenariat avec MARS (Mons Arts de la Scène) et avec le soutien de la Ville de Mons, l'ORCW présente un répertoire diversifié et original, avec des musiciens de grande renommée, belges et étrangers. Il présente des concerts pour le jeune public. Il offre des prestations aux jeunes artistes de l'Académie de musique de Mons et d'ARTS2 (École Supérieure des Arts).

a.s.b.l. - Hôtel de Ville - Jardin du Mayeur - Grand Place, 22 - B - 7000 Mons - Tél. +32(0)65/84.70.44 - [infos@orcw.be](mailto:infos@orcw.be)